

**Class I + Class II, Four poles Surge Arresters**
**BPS12.5V...4P**

Basic circuit diagram

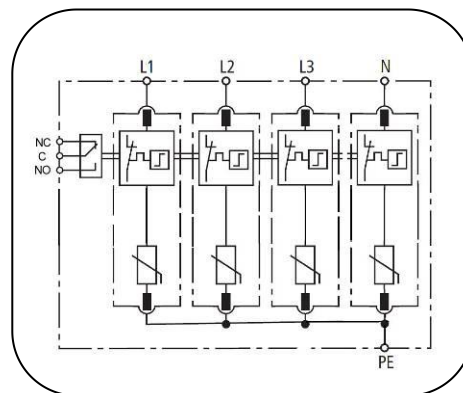
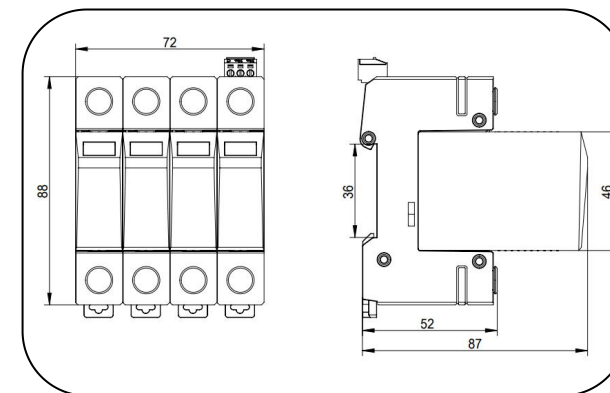

Dimension drawing

The BPS12.5V 4P is class I & class II (or T1+T2 ) prewired four poles SPD designed for low-voltage power system lightning current & surge protection, especially for location of high risk exposure or LPZ 0-2 building entrances ( IEC 62305-4) to against the damage from direct or close lightning strikes.

With built in PROSURGE high energy MOV, BPS12.5V 4P ensures remarkable lightning current discharge capacity up to 12.5kA 10/350 $\mu$ s. The unique design of thermal protection provides quick thermal response and secure disconnection. BPS12.5V 4P is ideal protection for environments with frequent switching operations or lightning strikes.

- TUV certified T1+ T2 SPD per IEC/EN 61643-11 standard.
- Prewired three poles SPD (“4+0” circuit) for use in three phase TN / TT systems.
- 18mm narrow model design, pluggable module for easy replacement without the need to remove system wiring.
- Unique thermal disconnecter design provides quick thermal response and secure disconnection
- Lightning current capacity up to 12.5kA10/350  $\mu$  s
- Surge current capability up to 80kA 8/20  $\mu$  s
- Low voltage protection level
- High short-circuit current rating up to 50kArms, suitable for application in most AC power systems.
- Degradation failure indication and optional remote signal contact.
- Wide operating temperature -40° C ~85° C
- 35mm DIN-rail mounting
- Comply with UL1449 5<sup>th</sup>, IEEE C62.41,CSA C22.2 standards

## POWER SUPPLY SYSTEM

### Technical data

Part No.	BPS12.5V/75(-S)/4P	BPS12.5V/150(-S)/4P	BPS12.5V/180(-S)/4P	BPS12.5V/275(-S)/4P	BPS12.5V/320(-S)/4P	BPS12.5V/350(-S)/4P	BPS12.5V/385(-S)/4P	BPS12.5V/440(-S)/4P	BPS12.5V/480(-S)/4P	BPS12.5V/600(-S)/4P	BPS12.5V/750(-S)/4P
In accordance with	IEC/EN 61643-11:2011; UL1449 5th										
Category IEC/EU/VDE	I+ II /1+2/ B+C										
Protection mode	L-PE, N-PE										
Nominal Voltage (AC) $U_n$	60V	120V	120V	230V	230V	277V	277V	400V	400V	480V	600V
Power frequency	50/60Hz										
Max. continuous operating voltage(AC) $U_c$	75V	150V	180V	275V	320V	350V	385V	440V	480V	600V	750V
Nominal discharge current(8/20) $I_n$	25kA										
Max. discharge current(8/20) $I_{max}$	80kA	80kA	80kA	80kA	80kA	80kA	80kA	65kA	65kA	65kA	65kA
Lightning impulse current (10/350) $I_{imp}$	12.5kA	12.5kA	12.5kA	12.5kA	12.5kA	12.5kA	12.5kA	8kA	8kA	6kA	4kA
Voltage protection level $U_p$	0.6kV	0.8kV	1.0kV	1.2kV	1.4kV	1.5kV	1.8kV	2.0kV	2.2kV	2.5kV	2.8kV
Response time $t_A$	$\leq 25$ ns										
Temporary overvoltage TOV $U_T$ Withstand mode	90V/5s	174V/5s	228V/5s	335V/5s	335V/5s	403V/5s	403V/5s	580V/5s	580V/5s	700V/5s	870V/5s
Follow current & interrupt rating $I_{fi}$	No										
Leakage current $I_{pe}$	$< 0.1$ mA										
Short-circuit current rating $I_{sscr}$	50 kArms										
Backup fuse(only required if not already provided in mains)	$\leq 250$ A gL/gG										
Operating temperature range	$-40^\circ\text{C} \sim +85^\circ\text{C}$										
Altitude	$-500\text{m} \sim +4000\text{m}$										
Cross-section of connection wire (max)	Single-strand 35mm <sup>2</sup> ; multi-strand 25mm <sup>2</sup>										
Mounting	35mm DIN-rail in accordance with EN 50022/DIN46277-3										
Enclosure material	Thermoplastic; extinguishing degree UL94 V-0										
Degree of protection	IP20										
Installation width	4 module, DIN 43880										
Thermal disconnecter	Internal Green – normal ; red - failure										
Remote alarm contact	Optional										
Approvals, Certifications	TUV, CE										
Additional data for Remote Alarm Contacts											
Remote alarm contact type	Isolated Form C										
Switching capability $U_n/I_n$	AC: 250V/0.5A DC: 250V/0.1A; 125V/0.2A; 75V/0.5A										
Cross-section of remote signaling wire	Max. 1.5mm <sup>2</sup> (or # 16AWG)										